

# R CRANK CASE COVER RING

APPLICATION: MONKEY125 (JB03) / DAX 125 (JB04) / GROM (JC92) / SUPER CUB C125 (JA58)

CODE : ( RED ) 307-1301620

CODE : ( BLACK ) 307-1301650

Thank you for purchasing Kitaco product. Read and understand the instruction before installing.

## ■ ATTENTION (MUST READ)

- This product is made for dress up and minimize the damage of crank case cover, etc, when falling. (Cannot prevent completely damage.) Do not use other purposes.
- This instruction sheet is for the instruction for genuine condition. Refer to the manufacturer service manual when installation.
- This product is designed and made exclusive for application vehicles, do not use other models. Do not modify the way which is not listed or it will cause damage and trouble.
- Please ask authorized mechanic for assembling and setting. Ask a specialist at specialty shop if you do not understand the role of the surrounding parts.
- Bolts and nuts may get loosen by engine vibration. Make sure not to loosen any bolts and nuts before driving.
- ※ Metal/resin/alumite products get discolored/rust for ages as well as how to use. Please understand when using.

PACKING LIST (Refer to the figure & illustration below.)				RED	BLACK	
FIGURE	NAME		CODE	QTY		REMARK
1	TOP RING	Red	307-1301600RD	1	-	
		BK	307-1301600BK	-	1	
2	CAP BOLT	M6x15	060-0500015	3	3	Tightening torque : 10N·m

## HOW TO INSTALL

※ If there is a hard degradation like a blem, fatigue and wear etc on the reuse parts, please change to new ones.

- 1) Remove 3pcs of genuine socket bolt, then remove R. crank case cover protector.
- 2) Install crank case cover top ring with attached bolts temporarily, follow the illustration below.
- 3) Tighten each bolts evenly with specified torque.

※ Tighten each bolts alternately evenly.

- 4) After installation, make sure not to loosen any bolts before riding.

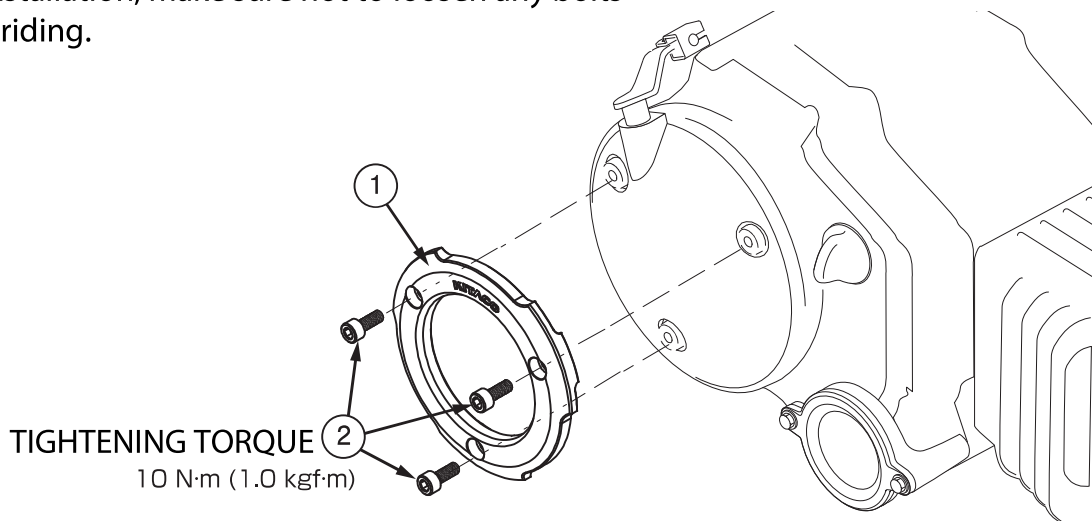

220928 M-T

〒 577-0015  
3-8-13

**KITACO**  
株式会社 千七

NAGATA, HIGASHI-  
OSAKA, OSAKA, JAPAN