

SUPER OIL COOLER KIT

SUPER OIL COOLER KIT (5-LAYER CONDENSOR)

CODE : 360-1083200

APPLICATION MONKEY/GORILLA/MONKEY BAJA FON,Z50J-1000001~/AB27-1000001~

● Thank you for purchasing Kitaco product. Read and understand the instruction before installing.

ATTENTION (MUST READ)

- It is to cool engine oil to avoid heating troubles to cause performance decrement.
- We are not responsible for violation of law or damages and accidents caused by assembling mistake and improper setting.
- Follow this instruction sheet. Do not modify the way which is not listed or it will cause damage and trouble.
- Please ask authorized mechanic for assembling and setting.
- Refer to the manufacturer service manual when installation.
- Bolts and nuts may get loosen by engine vibration.
- This product is designed and made exclusive for application models, do not use other models.



FLAMMABLES
Inflammable high oil is used during operation. Using products causing fire or smoke is strictly prohibited.



Engine oil is very hot during and after engine operation, so start work when the engine oil is cool enough (oil is hot even if the surface is cool).



Cylinders, crankcases, mufflers, etc. are very hot during and after engine operation and should not be touched carelessly.



This instruction sheet is for the person who has basic knowledge for maintenance. Do not operate if you do not have skill and knowledge.

● **KIT contents** (Please match the number in the drawing against to proceed with the work)

1. OIL COOLER	360-0500200	× 1	10. CONDENSER STAY	330-1083105	× 1
2. HOSE BAND (10~16)	995-0500016	× 4	11. M6×25 TRUSS BIS	066-0500025	× 2
3. OIL HOSE (60cm)	991-0000060	× 1	12. WASHER (6.5×16×1.6)	090-0907006	× 4
OUTLET UNIT SET	330-1083110	× 1	13. GROMMET COLLAR	093-0900003	× 2
4. OIL PLATE	330-1083111	(× 1)	14. GROMMET	752-9998099	× 2
5. UNION NIPPLE (BLUE)	990-0900900	(× 2)	15. U BOLT	060-0571064	× 1
6. UNION BOLT (RED)	771-0900900	(× 2)	16. M6 WASHER	090-0900006	× 2
7. 10mm BANJO ALUMINUM WASHER	771-0500999	(× 4)	17. M6 NUT	001-0500006	× 3
8. R CYLINDER HEAD SIDE COVER G/K	966-1015012	(× 1)	18. M6×10 CAP BOLT	060-0500010	× 2
9. 6mm ALUMINUM WASHER	964-1083010	(× 1)	19. M5×10 CAP BOLT	050-0500010	× 2
5. UNION NIPPLE (BLUE)	990-0900900	× 2	20. M5 NUT	001-0500005	× 2
6. UNION BOLT (RED)	771-0900900	× 2	21. L-SHAPED STAY	673-2011000	× 1
7. 10mm BANJO ALUMINUM WASHER	771-0500999	× 4			

1 3 0 7 1 7



<https://www.kitaco.co.jp/>

INSTALLATION OF OUTLET UNIT

Make sure the engine is cool before proceeding.

1. Remove three bolts from the R-side cylinder head, R-side cylinder head side cover and side cover GK. If the GK is sticking, remove it with a scraper.
2. Install the oil plate with the side cover GK and stock bolts.
※ Install the side cover GK so that the side with the OUTSIDE stamped on it is facing out.
※ Install the L-side head side cover and GK at the same time.
3. Temporarily tighten the union bolt, union nipple, and aluminum washer to the oil plate as shown in the figure.

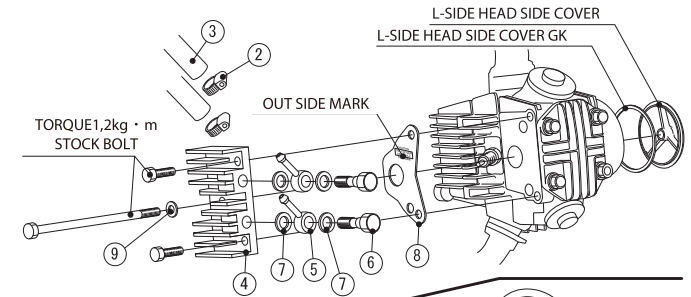

CONDENSER MOUNTING (MONKEY/GORILLA-6V)

4. Remove the frame clamber and tie them to the frame with tie-wraps, etc.
5. Install condenser stay with the two hex bolts.
6. Temporarily tighten the union bolt, union nipple, and aluminum washer to the oil plate.
7. Install condenser to the condenser stay with the truss bolts.
8. Cut the oil hose to an appropriate length and connect the condenser to the outlet unit with the hose band.
※ Adjust the direction of the union nipple and tighten the union bolts.
9. Add 150 cc of the engine oil and start the engine.
※ When starting the engine, do not blow the engine suddenly.

CONDENSER MOUNTING (MONKEY/GORILLA-12V/MONKEY BAJA)

4. Remove the frame clamber and tie them to the frame with tie-wraps, etc.
5. Install condenser stay with the supplied M5 cap bolt and M5 nut.
6. Temporarily tighten the union bolt, union nipple, and aluminum washer to the oil plate.
7. Install condenser stay with the supplied U-bolt, M6 nut and flat washer.
8. Install condenser to condenser stay with the truss bolts.
9. Cut the oil hose to an appropriate length and connect the condenser to the outlet unit with the hose band.
※ Adjust the direction of the union nipple and tighten the union bolts.
10. Add 150 cc of the engine oil and start the engine.
※ When starting the engine, do not blow the engine suddenly.

TORQUE	
6. UNION BOLT	1.5kg · m
11. M6×25 TRUSS SCREW	1.2kg · m
17. M6 NUT	1.2kg · m
18. M6×10 HEXAGONAL BOLT	1.2kg · m
19. M5×10 CAP BOLT	0.5kg · m

MONKEY/GORILLA-12V/MONKEY BAJA

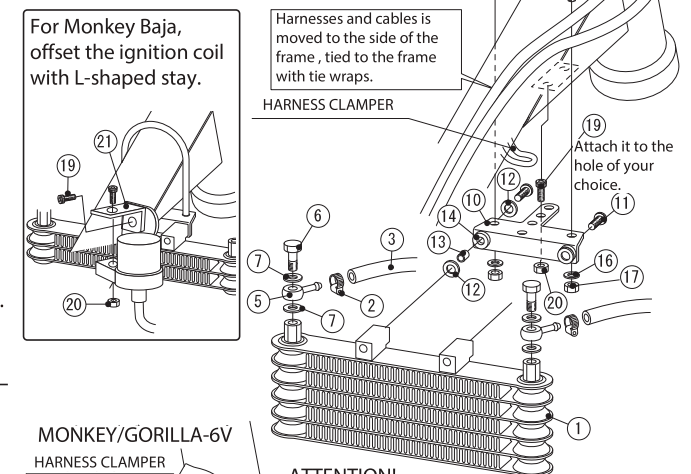

MONKEY/GORILLA-6V

