

**SUPER OIL COOLER KIT (3-LAYER), FOR CYLINDER HEAD LOWER MOUNT
(for KITACO CLUTCH KIT)**

CODE	(TAPPET CAP : BLACK) 360-1432800	(TAPPET CAP : SILVER) 360-1432810
APPLICATION	GROM (JC61)	
FEATURE	○Oil comes from Kitaco clutch cover ✕Stock R crankcase cover not useable	

- Thank you for purchasing Kitaco product. Read and understand the instruction before installing.
- Please keep the instruction for later needs. ✕This instruction is not included in replacement parts.

ATTENTIONS (MUST READ)

- Super oil cooler kit is for racing use only. Use this product with your responsibility.
 - This product is to cool engine oil to avoid heating troubles to cause performance decrement.
 - We are not responsible for damages and accidents caused by assembling mistake and improper setting.
 - Do not modify the way which is not listed or it will cause damage and trouble.
 - Please ask authorized mechanic for assembling and setting.
- Ask a specialist at specialty shop if you do not understand the role of the surrounding parts.
- Refer to the manufacturer HONDA service manual when installation.
 - Bolts and nuts may get loosen by engine vibration.
 - SUPER OIL COOLER KIT is designed and made exclusive for GROM, do not use on other models.

✕Metal / resin products will have rust for ages. Please understand when using.
✕Alumite products may get colored for ages. Please understand when using.



FLAMMABLES
Inflammable high oil is used during operation.
The use of products causing fire or smoke is strictly prohibited.

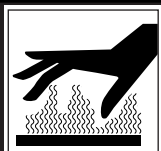

As for engine oil, during engine operation and after operation are extremely hot. Please start working after the oil cools down enough (it may be hot even when the surface is cool).



As for cylinder, crankcase, exhaust pipe, etc., during engine operation and after operation are extremely hot. Do not touch carelessly.



This instruction sheet is for the person who has basic knowledge for maintenance. Do not operate if you do not have skill and knowledge.

PACKING LIST (Refer to the figures & illustration right side)			360-1432800	360-1432810
FIGURE	NAME	CODE	QTY	
A1	TAPPET CAP (SILVER)	310-1432900	-	× 1
	TAPPET CAP (BLACK)	310-1432901	× 1	-
A2	MOUNT TAPPET CAP (SILVER)	310-1432910	-	× 1
	MOUNT TAPPET CAP (BLACK)	310-1432911	× 1	-
A3	CAP BOLT M6 × 15	060-0500015	× 4	× 4
A4	CAP BOLT M6 × 18	060-0500018	× 2	× 2
B1	OIL COOLER CONDENSER (3-LAYER)	360-0500100	× 1	× 1
B2	ALUMINUM SEALING WASHER · 10mm	771-0500999	× 7	× 7
B3	OIL NIPPLE (BLACK)	0900-990-90022	× 1	× 1
B4	UNION BOLT (RED)	771-0900900	× 1	× 1
B5	UNION NIPPLE (BLACK) 10mm	0900-990-90030	× 3	× 3
B6	OIL COOLER HOSE 100CM	991-0000100	× 1	× 1
B7	STAINLESS STEEL BAND (Φ8-12)	995-0500012	× 4	× 4
C1	OIL COOLER STAY	360-1432705	× 1	× 1
C2	CAP BOLT M6 × 25	060-0500025	× 2	× 2
C3	FLAT WASHER 6.5 × 16 × 1.6	090-0907006	× 8	× 8
C4	GROMMET COLLAR (6.2 X 7.5 X 7)	093-0900003	× 4	× 4
C5	GROMMET (7.5 X 9 X 7.5)	752-9999099	× 4	× 4

Reuse Honda genuine parts if they are not in the kit.
Change the reusing parts with new parts if there are significant blem, fatigue and wear.

About Kitaco CRANKCASE COVER oil line (extract)

- Make sure to start operation after engine cools down enough.
- Remove oil gallery out of oil line. Exchange them to oil nipple & aluminum washers in the kit.
- Tighten bolts & nuts with specified tightening torque.

TIGHTENING TORQUE N · m (1kgf · m : 9.80665N · m)		
NAME	QTY	REFERENCE
UNION BOLT (REUSE)	× 2	15N · m

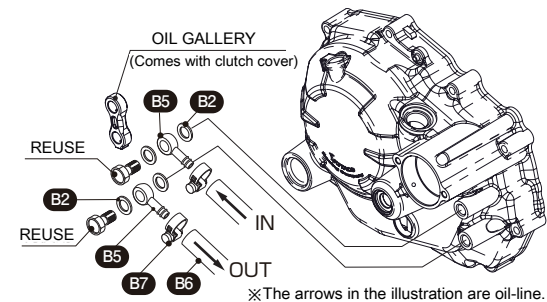

How to install condenser

•Assemble oil cooler temporarily and decide where to route the hose. Then, cut the oil hose, connect it to other parts.
Keep the oil hose away from muffler / engine.

- Tighten bolts & nuts with specified torque.
- Add engine oil (standard amount + 75 ~ 100cc) for oil cooler capacity.
- Make sure that the all the bolts & nuts are tightened, no oil leakage & no loosening before you drive.

✕Do not start engine quickly.
Keep idling before oil goes all inside the cylinder head lubrication.

Reuse Honda genuine parts if those are not in the kit.
•Change the reusing parts with new parts if there are significant blem, fatigue and wear.

Tightening torque N · m (1kgf · m : 9.80665N · m)				
FIGURE	NAME	QTY	REFERENCE	
A3	CAP BOLT M6 × 15	× 4	12N · m	
A4	CAP BOLT M6 × 18	× 2	15N · m	
B3	OIL NIPPLE	× 1	15N · m	
B4	UNION BOLT	× 1	15N · m	
C2	CAP BOLT M6 × 25	× 2	12N · m	

