

CHAIN ADJUSTER

APPLICATION : MONKEY 125 (JB02)

CODE (RED) 519-1300920 (BLACK) 519-1300950 (SILVER) 519-1300960 (GOLD) 519-1300970

● Thank you for purchasing Kitaco product. Read and understand the instruction before installing.

ATTENTION (MUST READ)

- This product is designed and made exclusive for application vehicles, do not use other models. Do not modify the way which is not listed or it will cause damage and trouble.
- We are not responsible for violation of law or damages and accidents caused by assembling mistake and improper setting.
- Please ask authorized mechanic for assembling and setting.
- Refer to the manufacturer service manual when installation.
- This instruction sheet is for the instruction for genuine condition.
- ※ Metal/resin/alumite products get discolored/rust for ages as well as how to use. Please understand when using.

PACKING LIST

FIGURE	NAME	CODE	QTY
-	CHAIN ADJUSTER	-	× 2

HOW TO INSTALL

- Stable vehicle with maintenance stand.
- Remove rear axle shaft.
- Remove swing arm genuine chain adjuster bolt, then change to Kitaco one. (Refer to the illustration below.)
- Tighten rear axle shaft and nut temporarily.
- Install chain adjuster evenly on the left and right, then adjust tension of the chain.
- Tighten rear axle nut with specified torque.
- Make sure not to loosen any parts before test ride.

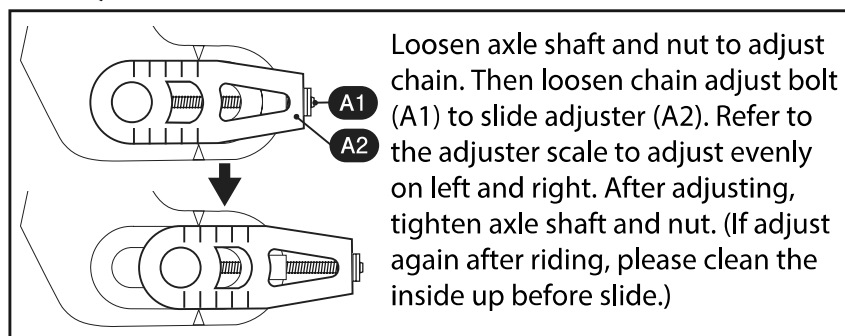
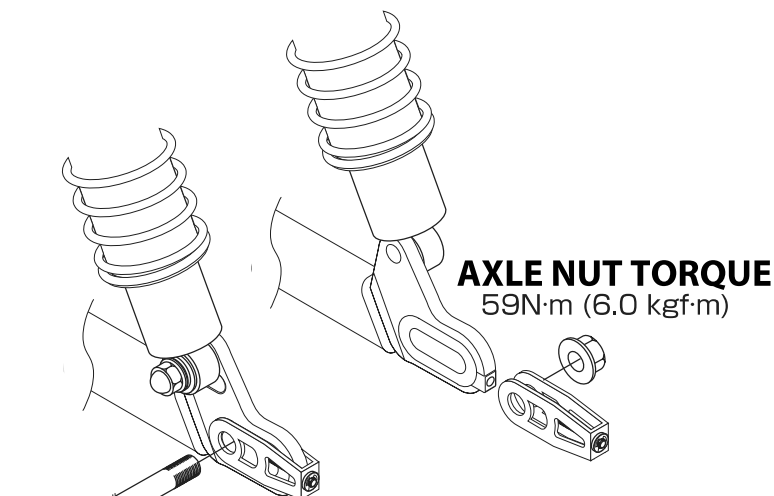

180606 S-N

KITACO
株式会社 キットコ

〒 577-0015

3-8-13

NAGATA, HIGASHI-

OSAKA, OSAKA, JAPAN