

FRONT CARRIER

CODE	80-539-13202
APPLICATION	DAX 125 (JB04)
REMARK	

Thank you for purchasing Kitaco product. Read and understand the instruction before installing.

ATTENTIONS (MUST READ)

- This instruction sheet is for the instruction for genuine condition.
- FRONT CARRIER is designed and made exclusive for DAX125 (JB04), do not use other models. Do not modify the way which is not listed or it will cause damage and trouble.
- Please ask authorized mechanic for assembling and setting. Ask a specialist at specialty shop if you do not understand the role of the surrounding parts.
- Refer to the manufacturer service manual when installation.
- Bolts and nuts may get loosen by engine vibration. Make sure not to loosen any bolts and nuts before driving.

Do not apply excessive force to carrier when you use rope or tie to deliver the vehicle. It might damage the front carrier or surrounding parts.

Do not overweight on carrier. It might damage the carrier. **(Weight limit:2.0kg)**

Do not put on things to prevent handling. This carrier is for assistance.

PACKING LIST			
FIGURE	NAME	CODE	QTY
1	FRONT CARRIER	539-1320001	x1
2	SPACER COLLAR 6.5x16xT10	539-1320002	x2
3	CAP BOLT M6x40	060-0500040	x2
4	CAP BOLT M8x50	080-0500050	x2
5	SPACER COLLAR 8.2x16xT6	539-1470002	x2

POINTS OF INSTALLATION

※ If there is a hard degradation like a blem, fatigue and wear etc on the reuse parts, please change to new ones. Install fashion carrier to top/bottom bridge split bolt position and head light mounting position with attached bolts.

Installation work needs to fix vehicle such as to be suspend handle, etc., before installation to loosen top/bottom bridge split bolt that fixing front fork.

HOW TO INSTALL

- 1) Remove head light genuine mounting bolt and top bridge split bolt.
- 2) Install carrier refer to the illustration on the bottom with avoiding handle & cable.
- 3) Tighten carrier with ② collar 6.5x16xT10 and ③ bolt M6x40 temporarily between head light and bracket.
- 4) Displace tightened carrier a little temporarily install ⑤ collar 8.2x16x6 to top bridge side and put in ④ bolt M8x50.
- 5) Tighten 4 spots of bolts alternately evenly. (Tighten top bridge bolts with specified torque)

TORQUE MANAGEMENT IS NEEDED
If you do not follow the tightening torque of the split bolts of top/bottom bridge, front fork might come off while running. Make sure to tighten the bolts with specified tightening torque.

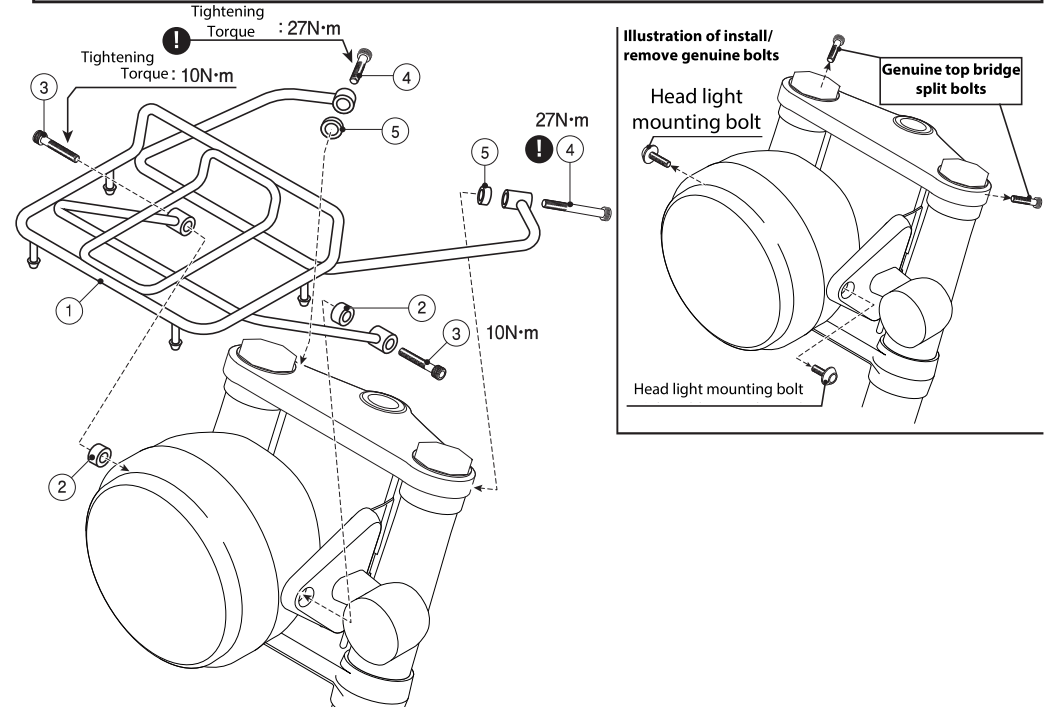

HOW TO INSTALL FRONT CARRIER

